



AARD SCALER LP



FEATURES

SAFE WORKING ENVIRONMENT

- Height adjustable canopy
- ISO ROPS/FOPS certified
- Spring applied, hydraulic release (SAHR) brakes
- Optional monitor (cameras) to increase operator's visibility during operation
- Door interlock

ENVIRONMENTAL

- Fuel efficient, clean burning Tier 2/Stage II engine
- Purifier with fume diluter

SERVICEABILITY

- All daily check points easily reachable
- Quick and easy service to increase productivity

- Air, hydraulic and transmission filter change indicators
- Easy access to service points, filters and valve blocks

OPERATOR'S COMFORT

- Comfortable T-back seat
- Stick steering ergonomically placed

RELIABILITY

- Proven hydrostatic powertrain
- Electric direction control in cab
- Machine status indication lights

SPECIFICATIONS

- Vehicle height 1 702mm
- Vehicle length 12 100mm
- Vehicle width 2 079mm
- Ground clearance 200mm
- Inner turning radius 3 750mm
- Outer turning radius 5 070mm
- Centre articulation 40°

ENGINE

- Type F6L914
- Power rating 79kW at 2 300rpm
- Torque 400Nm at 1 550rpm
- Fuel consumption 220g/kWh
- Engine protection As per customer requirements
- Air cleaner Two stage
- Catalytic converter
- Diluter

TRANSMISSION/TORQUE CONVERTER

- Hydrostatic transmission
- 125cc/rev piston pump with anti-stall automotive control
- Wheel motors

BRAKES

- Failsafe brake on all four wheels
- Park/emergency type SAHR
- Optional: hydraulically activated service brakes

TYRES

- Tyre size 35 x 15 – 15
- Designed for underground mine services
- Pneumatic or foam-filled

ELECTRICAL SYSTEM

- 24V system
- Alternator 28V / 55A
- Isolation switch lockout

HYDRAULIC SYSTEM

- System pressure 17.5MPa
- Pump type Gear
- Flow rate 2 x 36 litres/min at 2 300rpm
- Hydraulic tank capacity 150 litres
- Hydraulic level switch detection

FUEL SYSTEM

- Fuel tank capacity 150 litres

SAFETY

- Fire extinguisher
- Reverse hooter
- Door interlock
- Marker lamps red/green
- Wheel stop blocks

OPTIONAL EQUIPMENT

- Manually/automatically actuated fire suppression engine shut down
- Central lubrication management system

- Automatic lubrication system
- Halogen, LED or sealed beam lights
- Electrical gear control inside cab

DOCUMENTS

- Parts manual
- Technical manual
- Risk assessment

3D VIEW

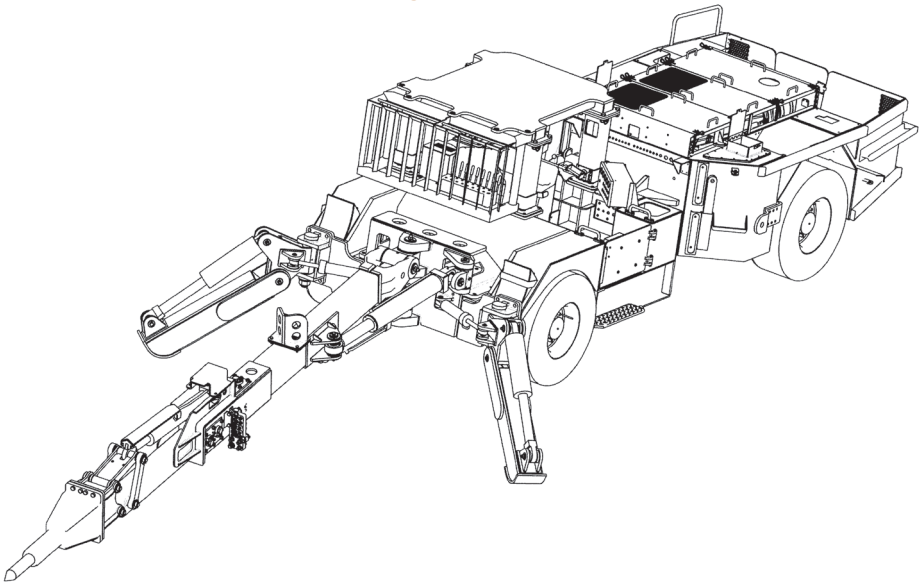

SCALE 1:500

TOP VIEW

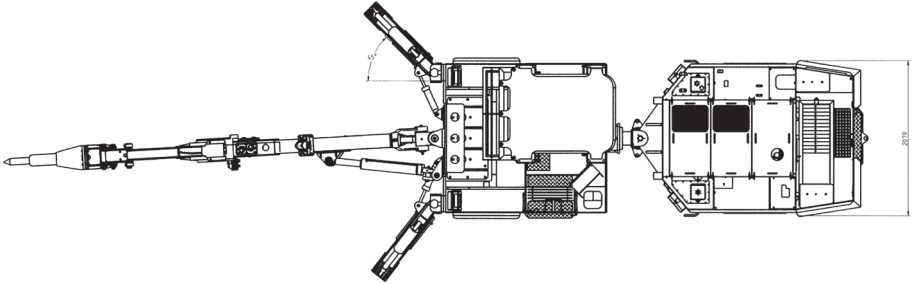

SIDE VIEW

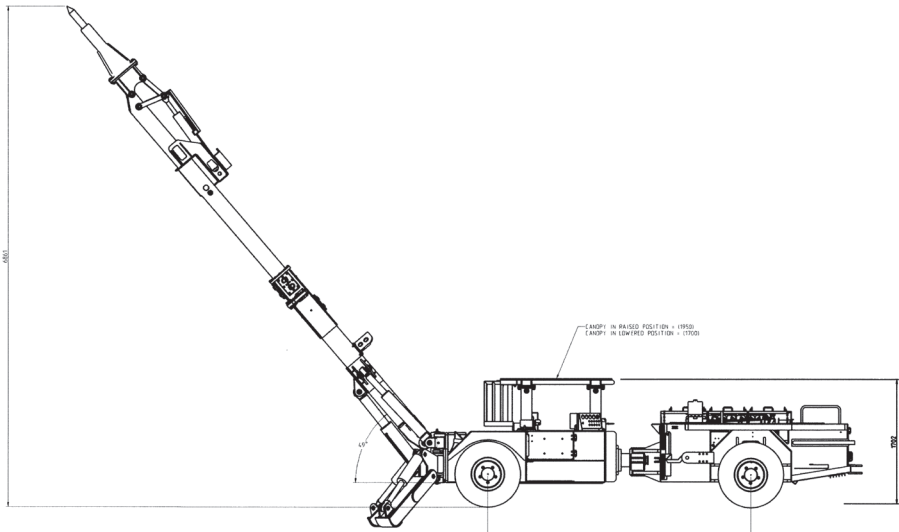

AARD Mining Equipment is constantly striving to improve its products and therefore reserves the right to change the designs, materials, specifications and price without prior notice.

PRODUCTS & EQUIPMENT

44 Jacobs St., Chamdor, 1739

PO Box 3992, Witbeek 1729, South Africa

E-mail: info@aardme.co.za

Website: www.aardme.com

