



# AARDRUNNER UV83



## FEATURES

### SAFE WORKING ENVIRONMENT

- ISO ROPS/FOPS certified
- Spring applied, hydraulic release (SAHR) brakes
- Optional monitor (cameras) to increase operator's visibility during operation
- Door interlock

### ENVIRONMENTAL

- Fuel efficient, clean burning Tier 2/Stage II engine
- Purifier with catalytic converter

### SERVICEABILITY

- All daily check points easily reachable
- Quick and easy service to increase productivity

- Air, hydraulic and transmission filter change indicators
- Easy access to service points, filters and valve blocks

### OPERATOR'S COMFORT

- Comfortable T-back seat
- Steering wheel ergonomically placed
- Single seat or dual seat compartment optional

### RELIABILITY

- Proven powertrain Clark powershift transmission
- Mechanical gear control in cab
- Machine status indication lights

## SPECIFICATIONS

■ Vehicle height	2 202mm
■ Vehicle length	7 244mm
■ Vehicle width	1 942mm
■ Ground clearance	310mm
■ Inner turning radius	3 550mm
■ Outer turning radius	5 500mm
■ Gross vehicle weight empty	7 100kg
■ Max. carrying capacity	8 000kg

## ENGINE

■ Type	F6L914
■ Power rating	79kW at 2 300rpm
■ Torque	400Nm at 1 550rpm
■ Fuel consumption	220g/kWh
■ Engine protection	As per customer requirements
■ Air cleaner	Two stage
■ Catalytic converter	
■ Diluter	

## TRANSMISSION/TORQUE CONVERTER

■ Three speed forward and reverse with integral converter	
■ Dana	T20 000 series

## AXLES

■ Dana	112
--------	-----

## BRAKES

■ Failsafe brake on all four wheels	
■ Type	SAHR

## TYRES

■ Tyre size	35 x 15 - 15
■ Designed for underground mine services	
■ Pnuematic or foam-filled	

## ELECTRICAL SYSTEM

■ 24V system	
■ Alternator	28V/55A
■ Isolation switch lockout	

## HYDRAULIC SYSTEM

■ System pressure	17.5MPa
■ Pump type	Gear pump
■ Flow rate	2 x 36 litres/min at 2 300rpm
■ Hydraulic tank capacity	150 litres
■ Hydraulic level switch detection	

## FUEL SYSTEM

■ Fuel tank capacity	85 litres
----------------------	-----------

### **SAFETY**

- Fire extinguisher
- Reverse hooter
- Door interlock
- Marker lamps red/green
- Wheel stop blocks

### **OPTIONAL EQUIPMENT**

- Manually/automatically actuated fire suppression engine shut down
- Central lubrication management system
- Automatic lubrication system
- Halogen, LED or sealed beam lights
- Electrical gear control inside cab

### **CRANE**

- Three stage telescopic boom
- Max lift height 4.50m from ground level with boom fully extended

Max. capacity

Reach

4.05m

3.00m

1.90m

Lifting

735kg

1 000kg

1 575kg

### **DOCUMENTS**

- Parts manual
- Technical manual
- Risk assessment

## TOP VIEW

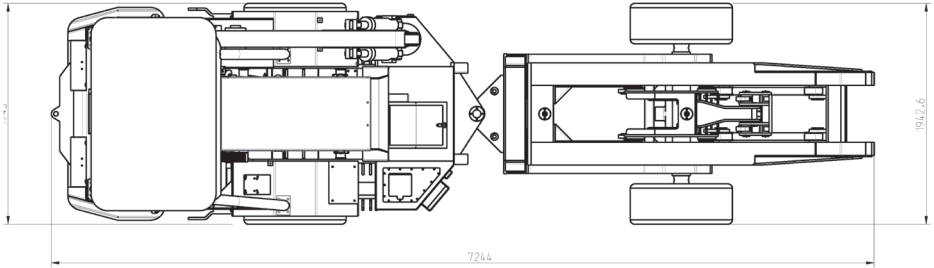

## SIDE VIEW

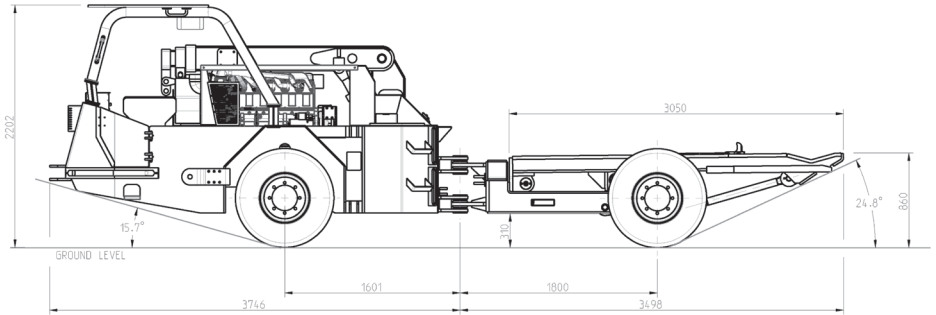

## SIDE VIEW

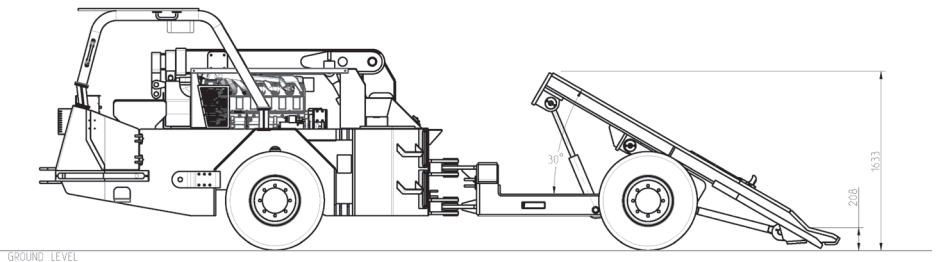

AARD Mining Equipment is constantly striving to improve its products and therefore reserves the right to change the designs, materials, specifications and price without prior notice.

### PRODUCTS & EQUIPMENT

44 Jacobs St., Chamdor, 1739  
PO Box 3992, Witbeek 1729, South Africa

E-mail: [info@aardme.co.za](mailto:info@aardme.co.za)

Website: [www.aardme.com](http://www.aardme.com)

